

SOVOL-SV02 Printer

Guidebook To:

Constructing Sovol's Top-quality 3D printer

- This guidebook is for Sovol's SV02 3D printer.
- Select the correct input voltage to match your local mains (220V or 110V).
- Please plug the power cord into a three-hole power jack.
- Detailed instructions for use are available on the SD card.

Notes

- 1 Do not use this machine in any way other than described herein. Failure to do so may result in personal injury and/or damage to property.
- 2 Do not place the printer near any heat source or flammable or explosive materials. We suggest placing it in a well-ventilated, low-dust environment.
- 3 Do not expose the printer to violent vibration or any unstable environment, as this may cause poor print quality.
- 4 Before using experimental or exotic filaments, we suggest using standard filaments such as ABS or PLA to calibrate and test the machine.
- 5 Do not use any other power cable except the one supplied. Always use a grounded three-prong power outlet.
- 6 Do not touch the nozzle or printing surface during operation as they may be hot. Keep hands away from machine while in use to avoid burns or personal injury.
- 7 Do not wear gloves or loose clothing when operating the printer. Such cloths may become tangled in the printers moving parts leading to burns, possible bodily injury, or printer damage.
- 8 When cleaning debris from the printer hotend, always use the provided tools. Do not touch the nozzle directly when heated. This can cause serious burns and injuries.
- 9 Clean the printer frequently. Always turn the power off when cleaning, and wipe with a dry cloth to remove dust, adhered printing plastics or any other material off the frame, guide rails, or wheels . Use glass cleaner or isopropyl alcohol to clean the print surface before every print for consistent results.
- 10 Children under 10 years of age should not use the printer without supervision.

Contents

Preface

This Guide is designed for Sovol users and contains vital information regarding the SV02 to assist in your 3D printing journey.

We recommend that all users read and understand the information in this guide, even if you are familiar with 3D Printing technology.

Additional resources and information:

(1) Quick Start Guide

Quick Start with user guide or view the video on the TF card.

(2) Official Website: <http://www.sovol3d.com>





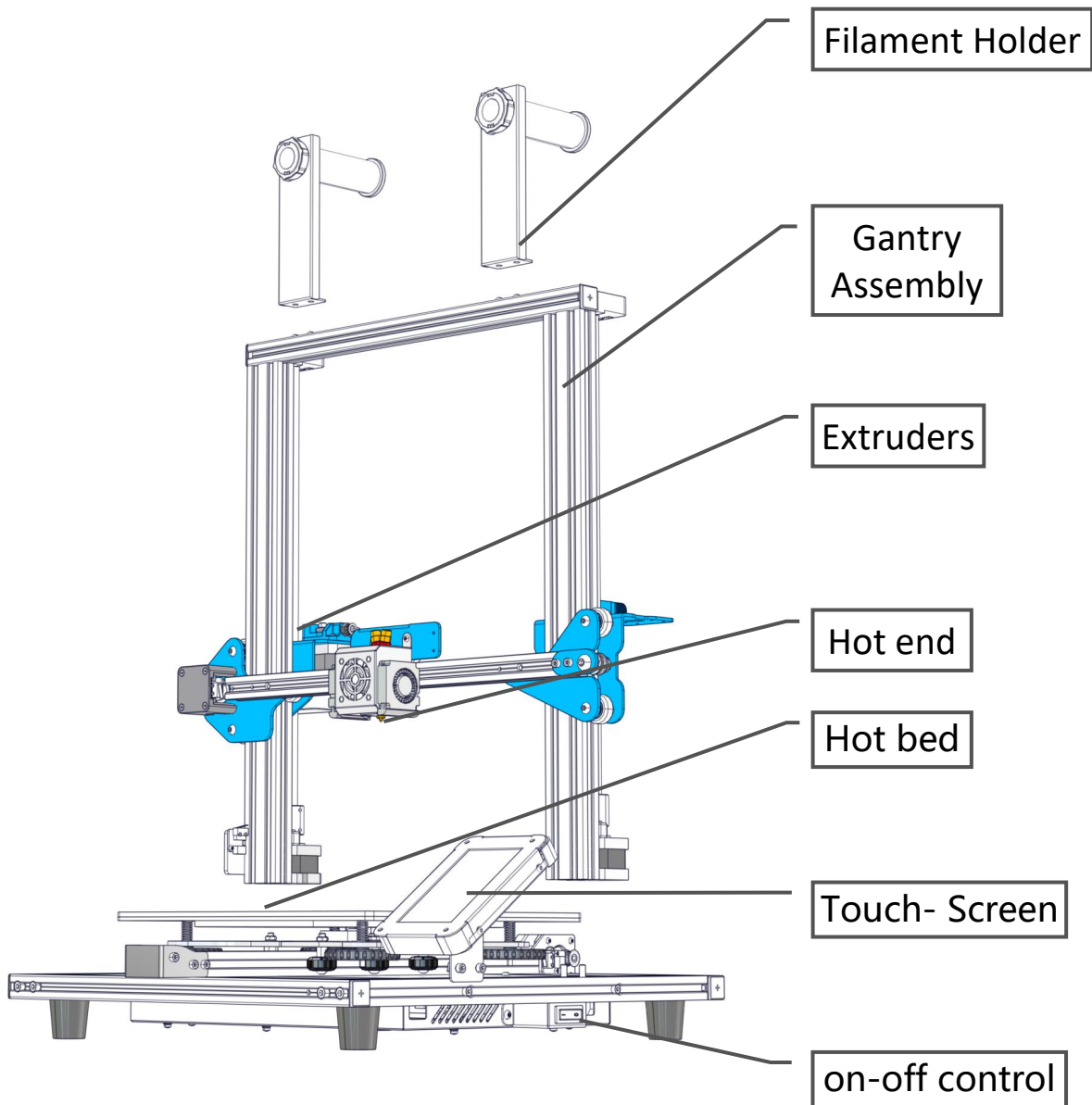

Find out all latest news which contains the up-to-date information concerning software, firmware, device maintenance and so on.

(3) Sovol User Group on Facebook. Be a part of the Sovol community sharing your projects and helping each other.

01	Contents
02	Introduction
03	General List
04	Assembly
06	Cable Connection
07	Screen Information
08	Loading Filament
09	Bed Leveling
10	Software Installation
11	Slicing
12	Preparing to printing
13	Circuit Wiring Diagram
14	After-Sales Service

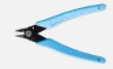

◆ Tool List 1

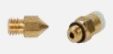
No.	Image	Name	Qty
1		Wrench & Screwdriver	1set
2		TF Card & Reader	1set
3		Spatula	1
4		Pliers	1
5		0.4mm Nozzle Cleaner	1
6		Power Cable	1
7		USB Cable	1
8		Spare Parts	1set

Gantry Assembly

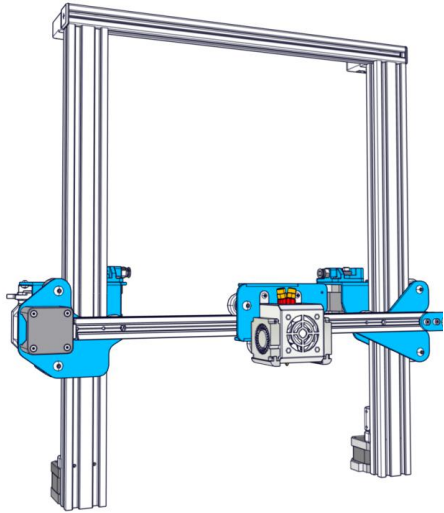

Base

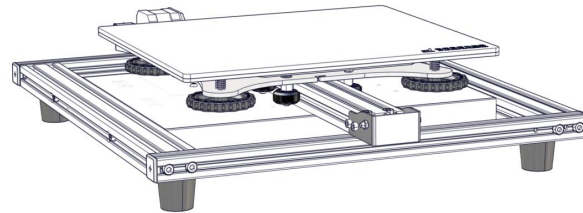

Display screen

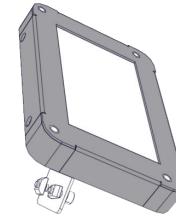

Filament Holder(*2)

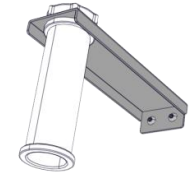





Tool Box

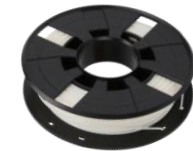

Filament (200g)



◆ Tool List 2

No.	Image	Name	Qty
9		M5x25 Black Hex-Bolt and Lock Washer	4
10		Z-axis limit plate assembly	1set
11		M3x4 Screw	4
12		Touch screen support	1

◆ Gantry Frame Installation

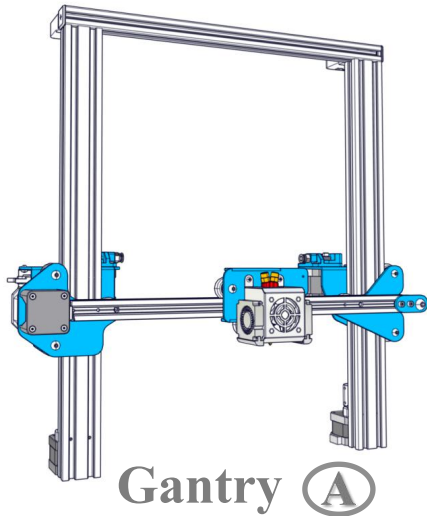

Back

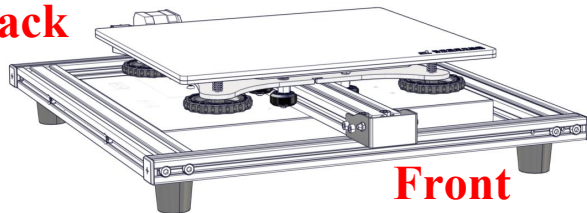

Base (B)



4pcs

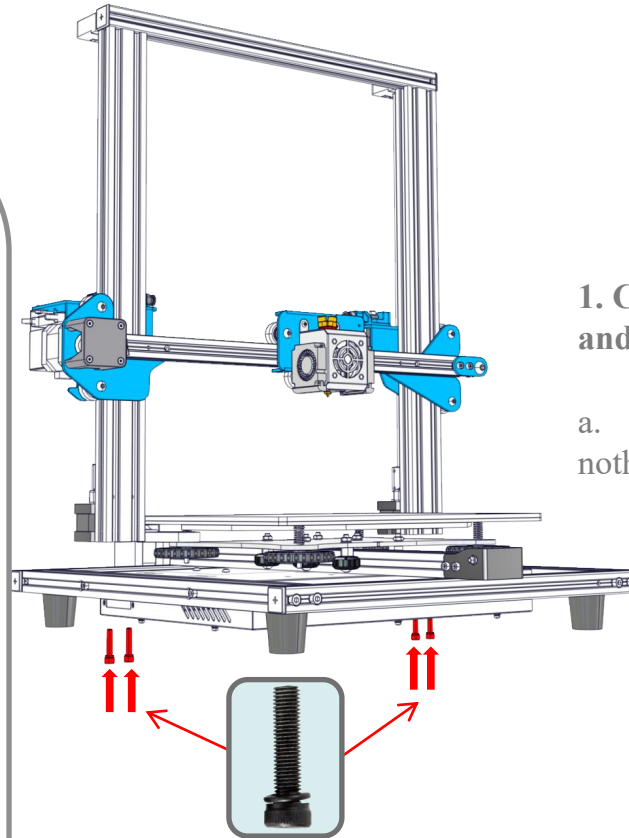

1. Carefully remove all parts from the box and remove any tape or padding from them.

a. Inspect each component and ensure nothing was damaged during shipment.

2. Install the gantry frame (A) to the base frame (B)

- a. On the gantry frame, make sure the nozzle assembly is to the front, and the long vertical lead screw is to the back. On the base frame, make sure the black belt cover is on the front, and the stepper motor is on the back.
- b. Use the M5x25 screws (4) and lock washers (4). Lift the base frame. Install the screws through the base frame into the threaded holes in the gantry frame. Tighten with the M5 hex key (Allen) wrench.

◆ Filament Holder Installation

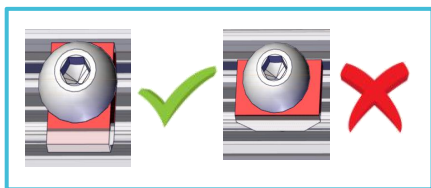
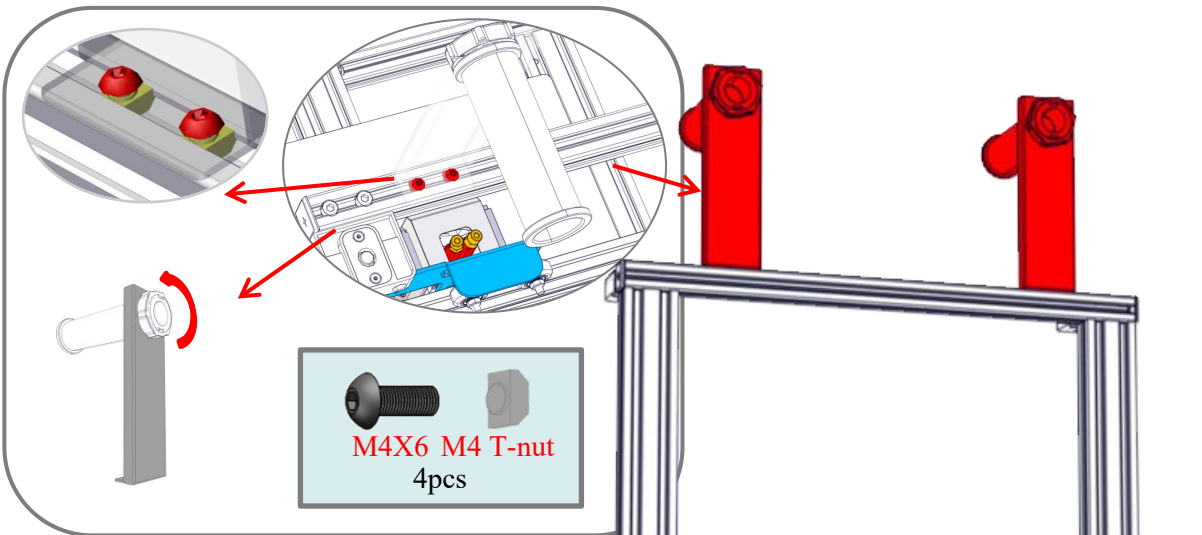

Ⓒ

◆ Z-axis limit plate installation

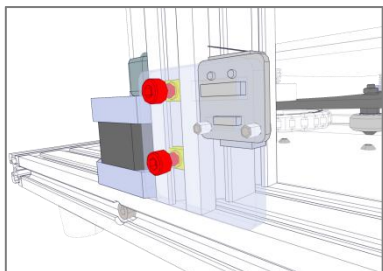

M4X10 M4 T-nut
2pcs

3. Installation of the filament spool holder.

- Secure the filament holder using two M4*8 screws and T-nuts. Loosen the t-nuts by hand and align them so they will fit inside the grooves of the frame. It is essential that the nuts are loose so that when you tighten the screws, the nuts will rotate 90° and grab onto the inside of the groove of the extrusion.
- Align the round cylinder through the hole of the filament plate. Turn the large nut to lock in place.

4. Installation of the Z-axis limit plate.

- The Z-axis limit switch board is installed at the lower left of the gantry, and the installation method is the same as that of the filament bracket.

5. Touch Screen Display installation.

- Attach the bracket to display with M3x4 screws (4)
- Mount the touchscreen to the front right side of the frame with M4x6 screws (2) and T-nuts (2).

◆ Display screen Installation

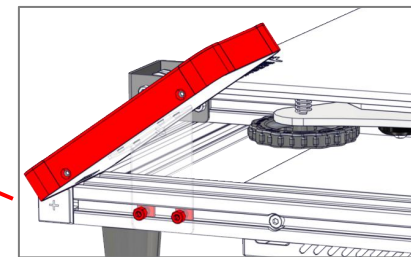

M4X6 M4 T-nut
2pcs

Tip: Try not to bend the pin connectors as you push them in. Pay attention to the working voltage of your machine



Touch Screen Cable

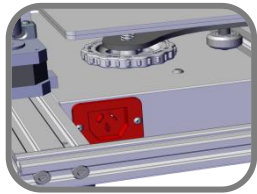

*Plug the power cord into a three-hole power jack.

The Y cables go to the motor and switch at the back of the base frame that move the build plate.

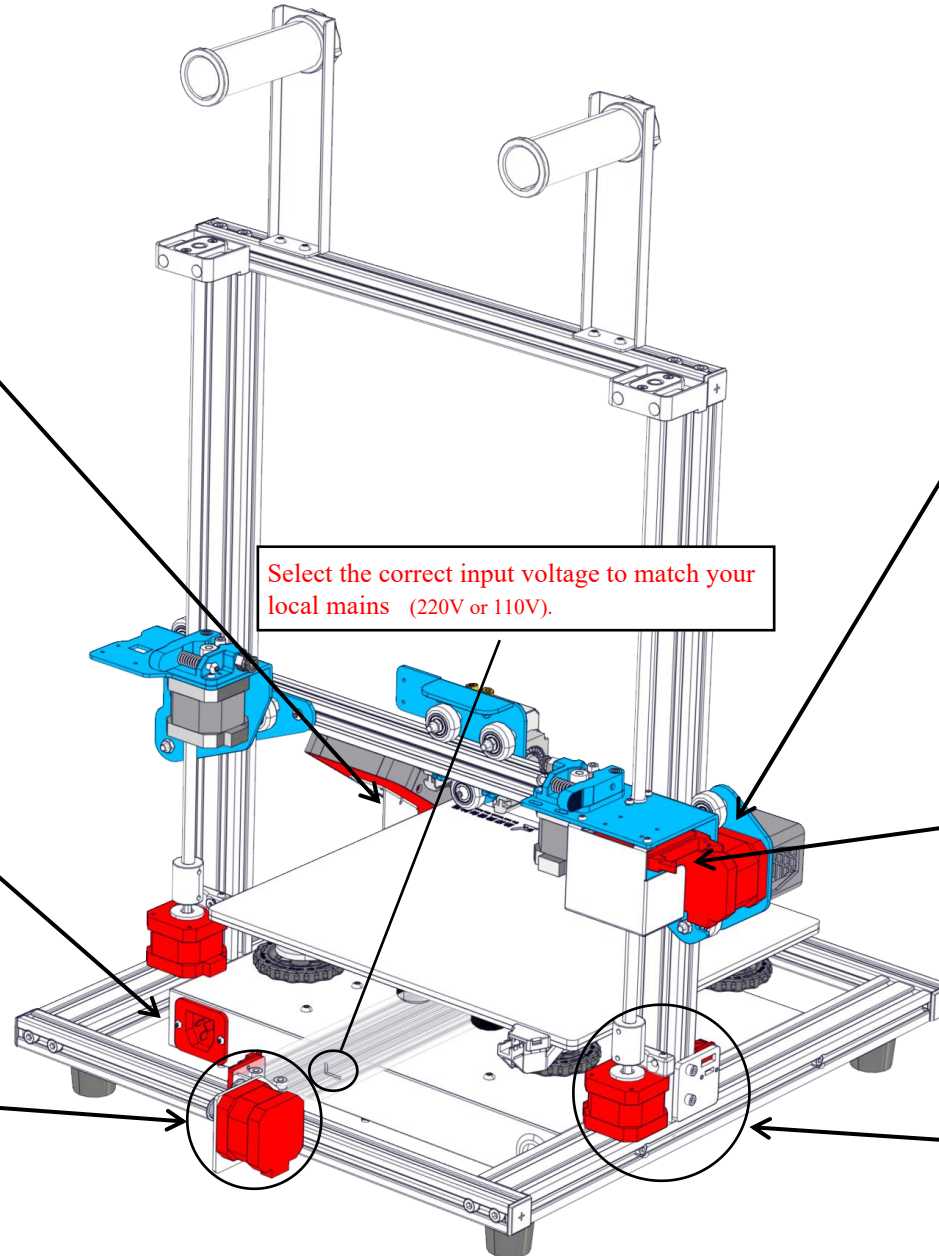
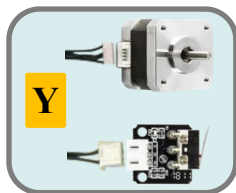

Select the correct input voltage to match your local mains (220V or 110V).

The X cable is connected to the motor and running belt switch

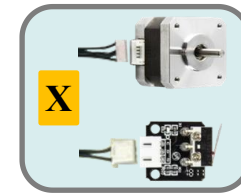

Ribbon Cable



The Z cables go to the motor and switch on the left side of the base frame that raise and lower the nozzle.

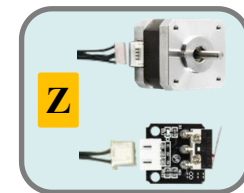

Information Displayed

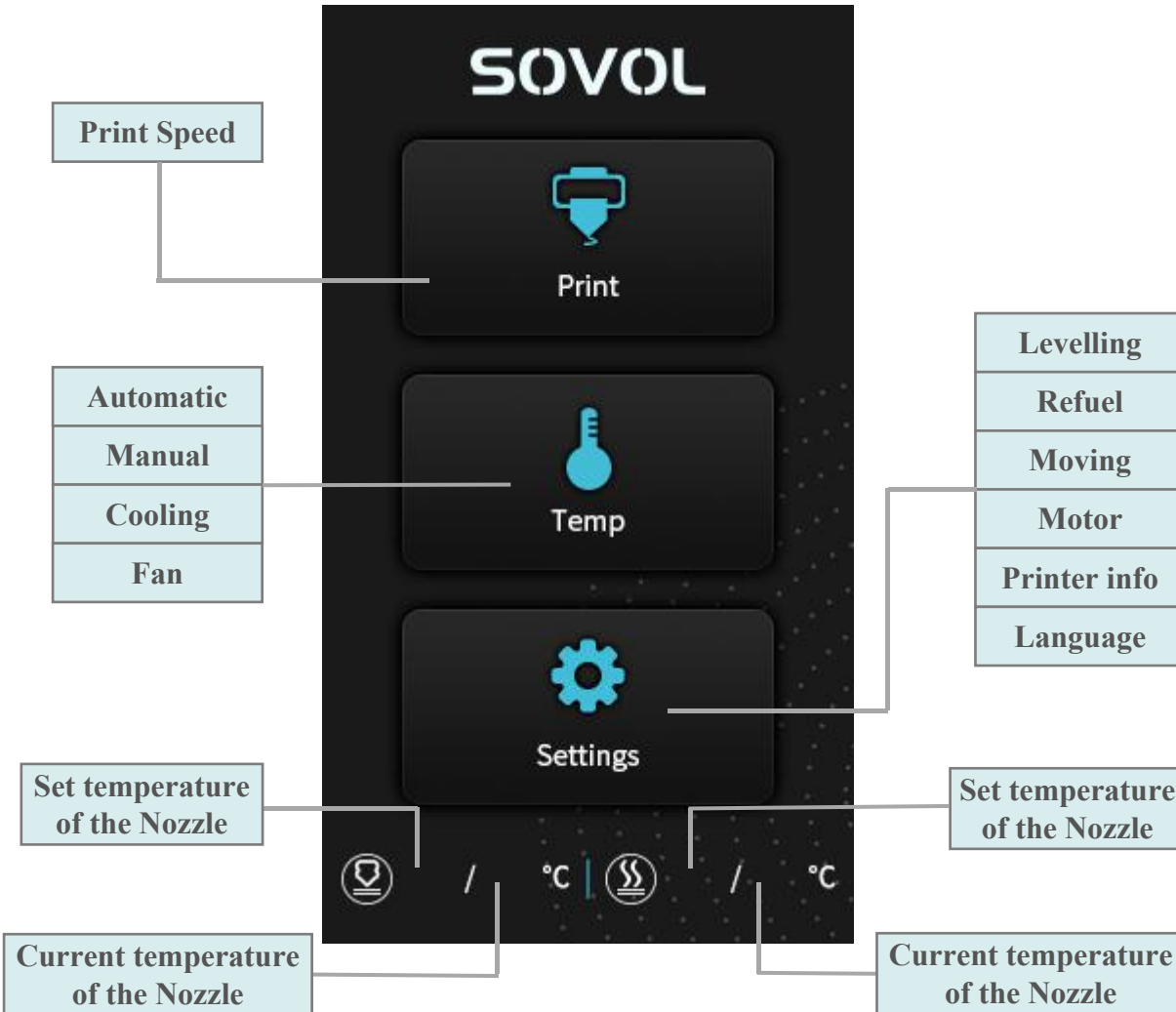

Screen Information				
Main Menu	Sub Menu	Explanation		
TF card	Selected file	Adjust	Stop	
			Pause/Continue	
			Print speed	
			Nozzle temp.	
			Hot-bed temp	
			Z offset	
			fan	
Temp	Automatic	PLA\ABS (195°\240°)		
	Manual	Nozzle preheat		
		Hot-bed preheat		
	Cooling	Cool down? Yes\No		
Fan	Turn on\Shut down			
Setting	Levelling	Z-axis: Z home, +0.1mm,-0.1mm		
		AUX leveling	Please click numbers to assist levelling (①~⑤)	
		AUTO leveling	Auto leveling, please wait...	
		Check level (Measurement parameters)		
	Refuel	Withdraw		
		Feed		
Moving	X-axis	Y-axis	Z-axis	Z home
Motor off	yes\no			
Language	English\Chinese			
Printer info	Machine type、 Firmware version、 Printing size、 website			

1. Preheat

Method 1

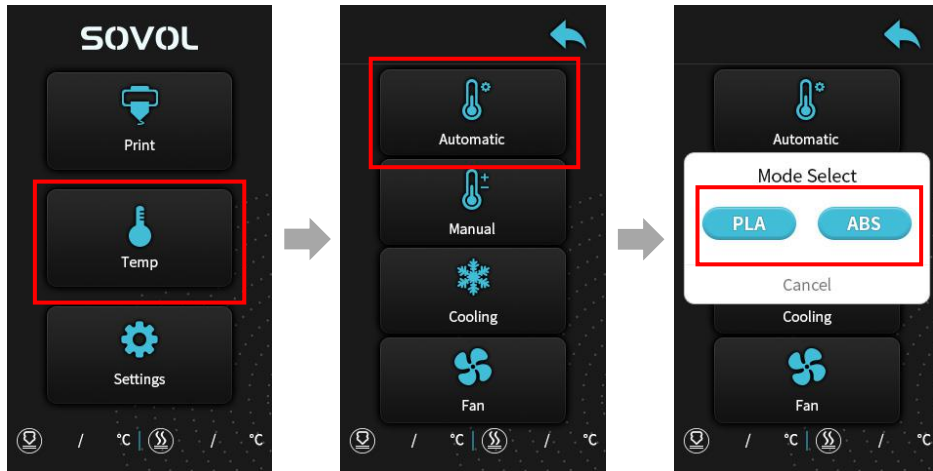

Method 2

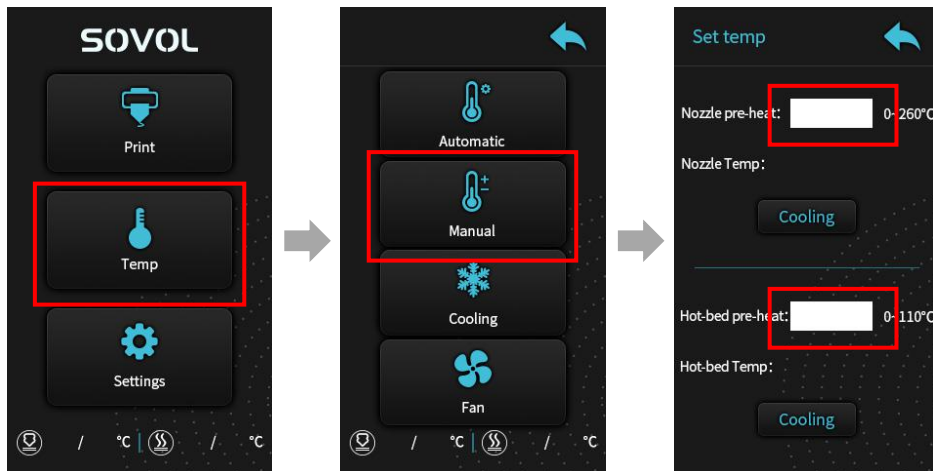

2. Feeding Filament

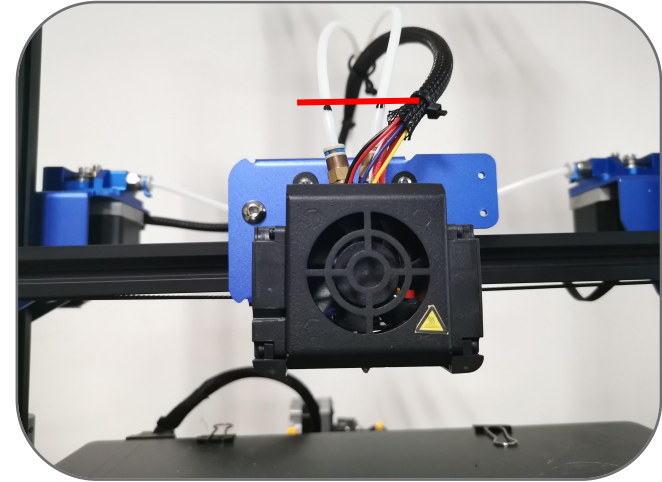

Press and hold the extrusion clip, insert the filament from the inlet to the position with red line above the small pneumatic connector.

Tip : How to Replace the Filament ?

1. Preheat the nozzle.

Push and hold extruder arm and feed 5-10mm of filament by hand, then quickly withdraw the filament.

Using this method helps to avoid pulling liquid filament through the PTFE tube, potentially causing clogs.

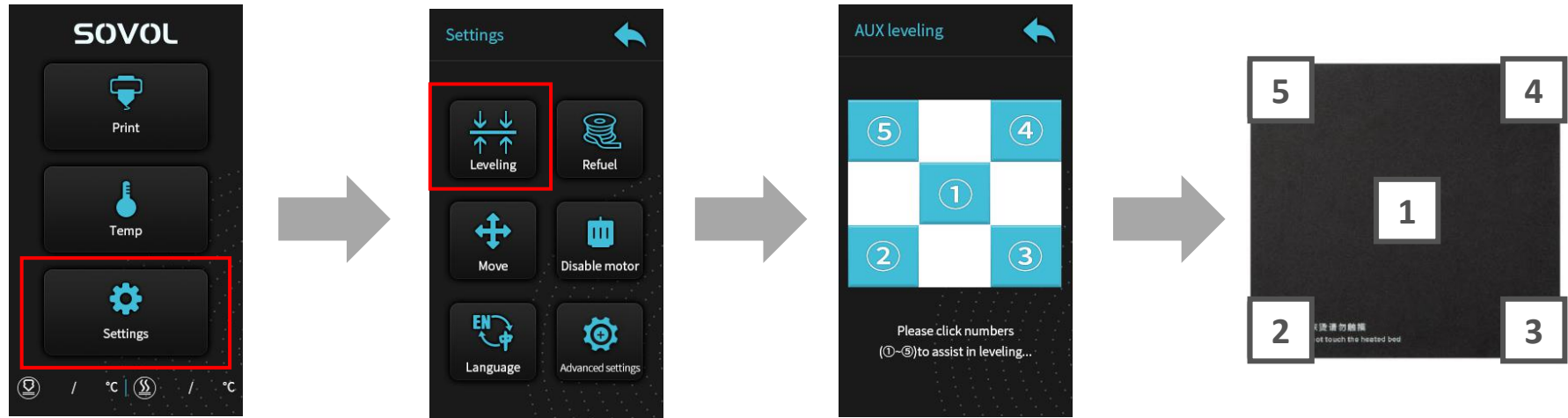

1. Tighten the four levelling nuts at the bottom of the platform before initial levelling.
2. Select Settings→Levelling, click on the number ②
3. Adjust the platform height by turning the knob underneath. Use a piece of A4 paper (standard printer paper) to assist with the adjustment, making sure that the nozzle lightly scratches the paper.
4. Complete the adjustment of the screw on all 4 corners.
5. Click the number ① to test whether the middle gap of the platform is suitable.
6. Repeat above steps 1-2 times if necessary.
7. Slight adjustments can be made while brim or first layer is printing.

Pro Tip: If the hot bed is not perfectly level and adjusted, the Z axis compensation function can be used when printing the first layer to get a perfect first layer.

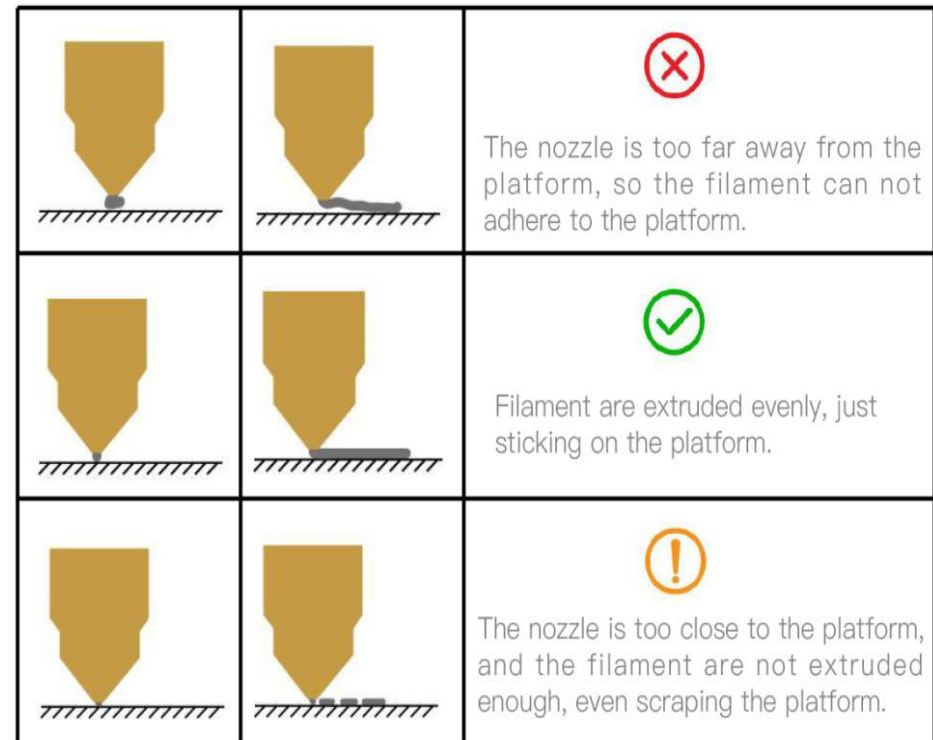
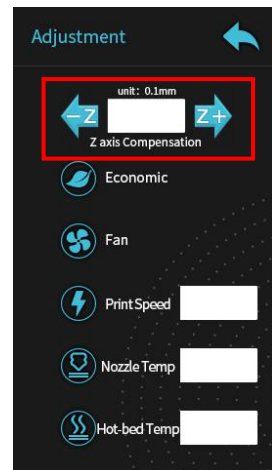



Cura.exe

1. Install the Cura 4.5

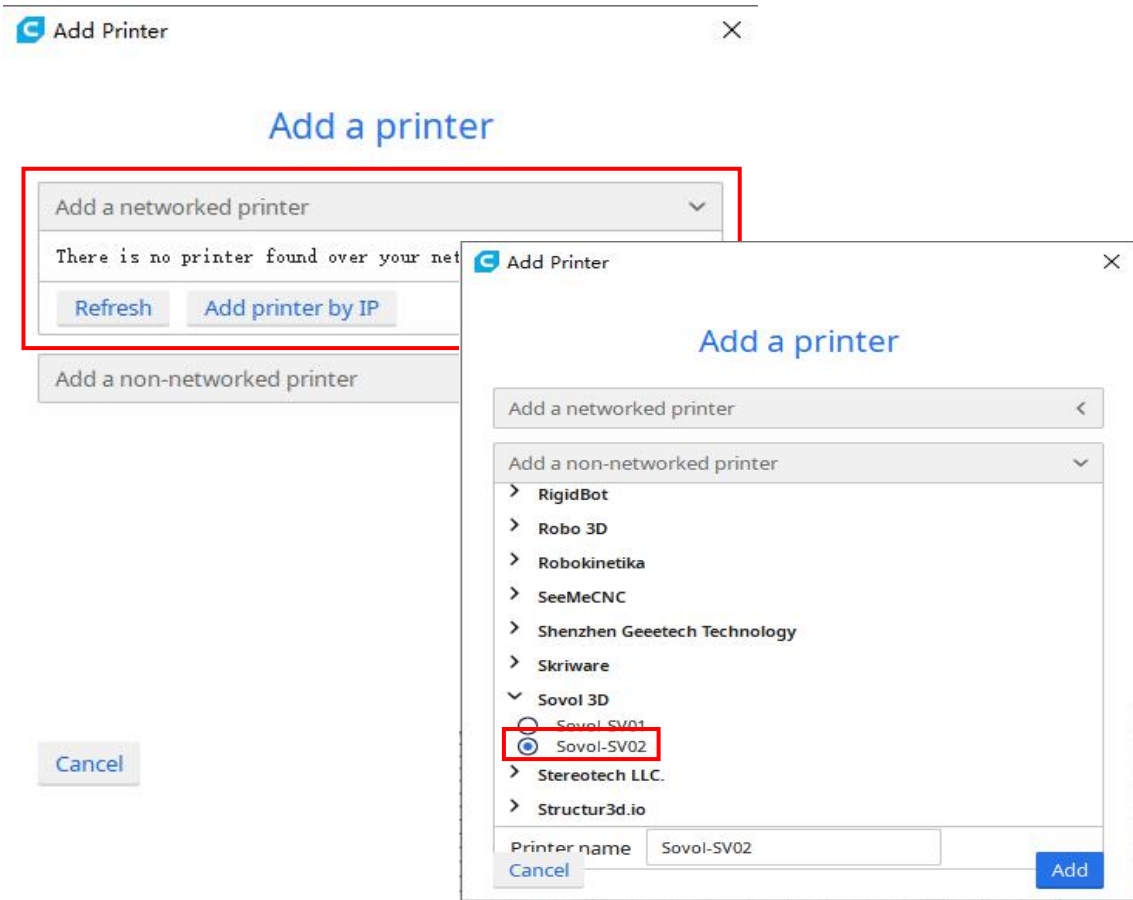

2. Add the machine

(How to add the choice of SV02 Machine in Cura, please refer to 'SV02 Machine Profile guide.docx' in the 'Machine Profile' folder in SD card.)

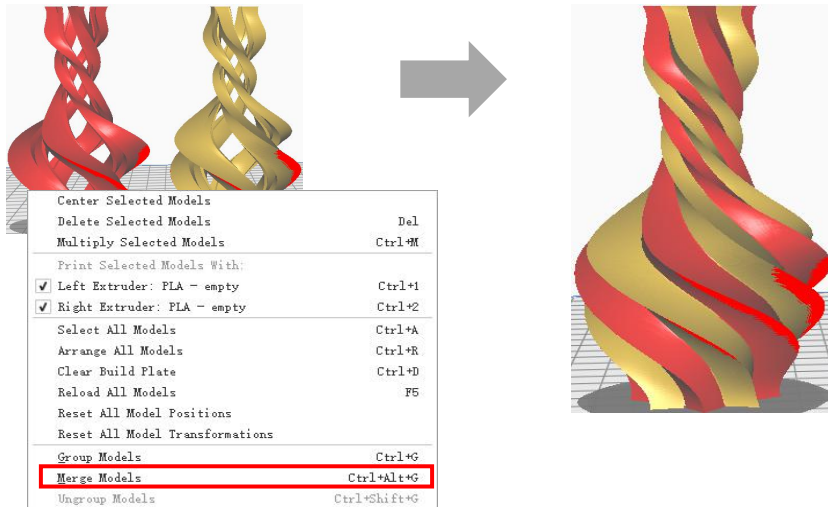

1. Add and merge the models

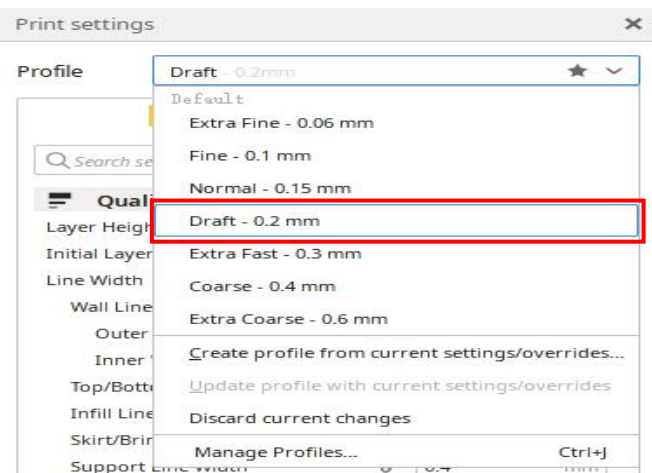

3. Select the profile "Draft"

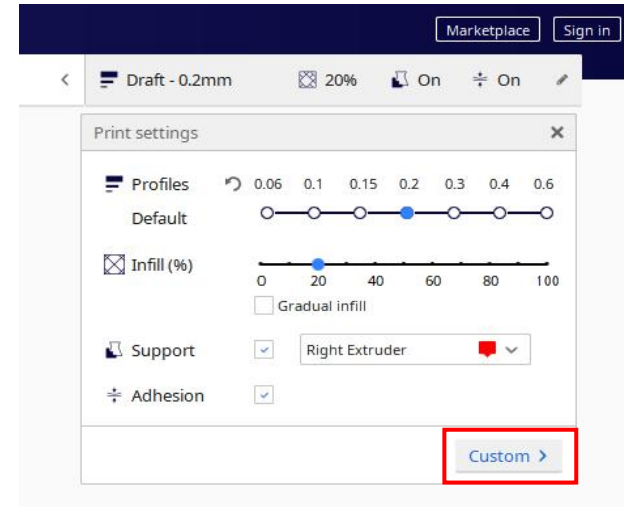

2. Select custom

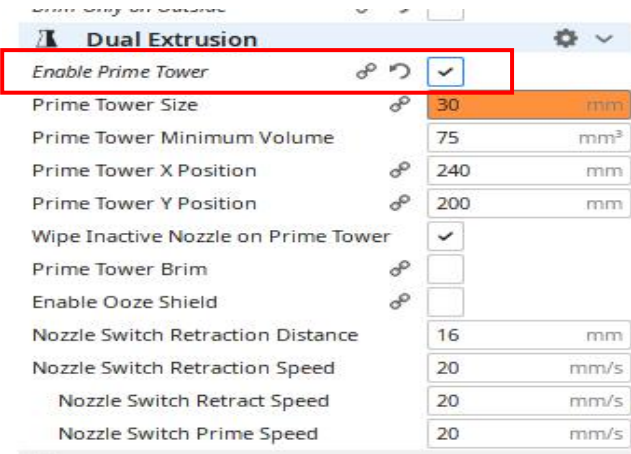

4. Select Enable Prime Tower

1. Save file to SD card

Insert SD card into computer with Reader.

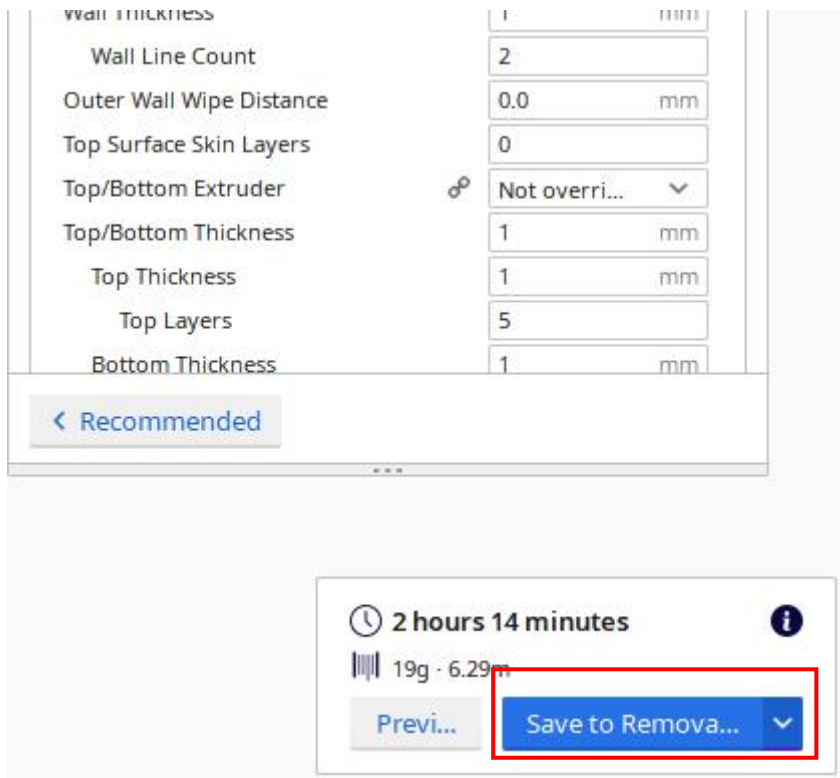

2. Printing



Insert the SD card

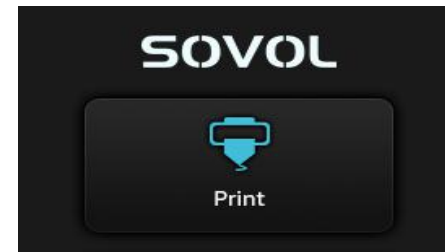

Select "Print from SD"

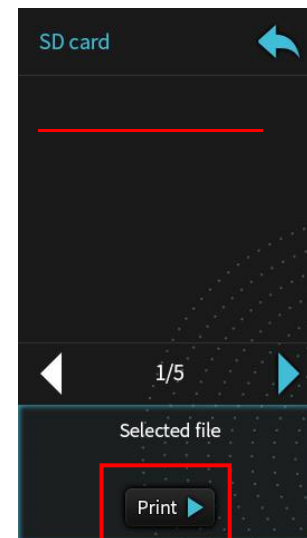

Select the file to be printed

Circuit Wiring Diagram

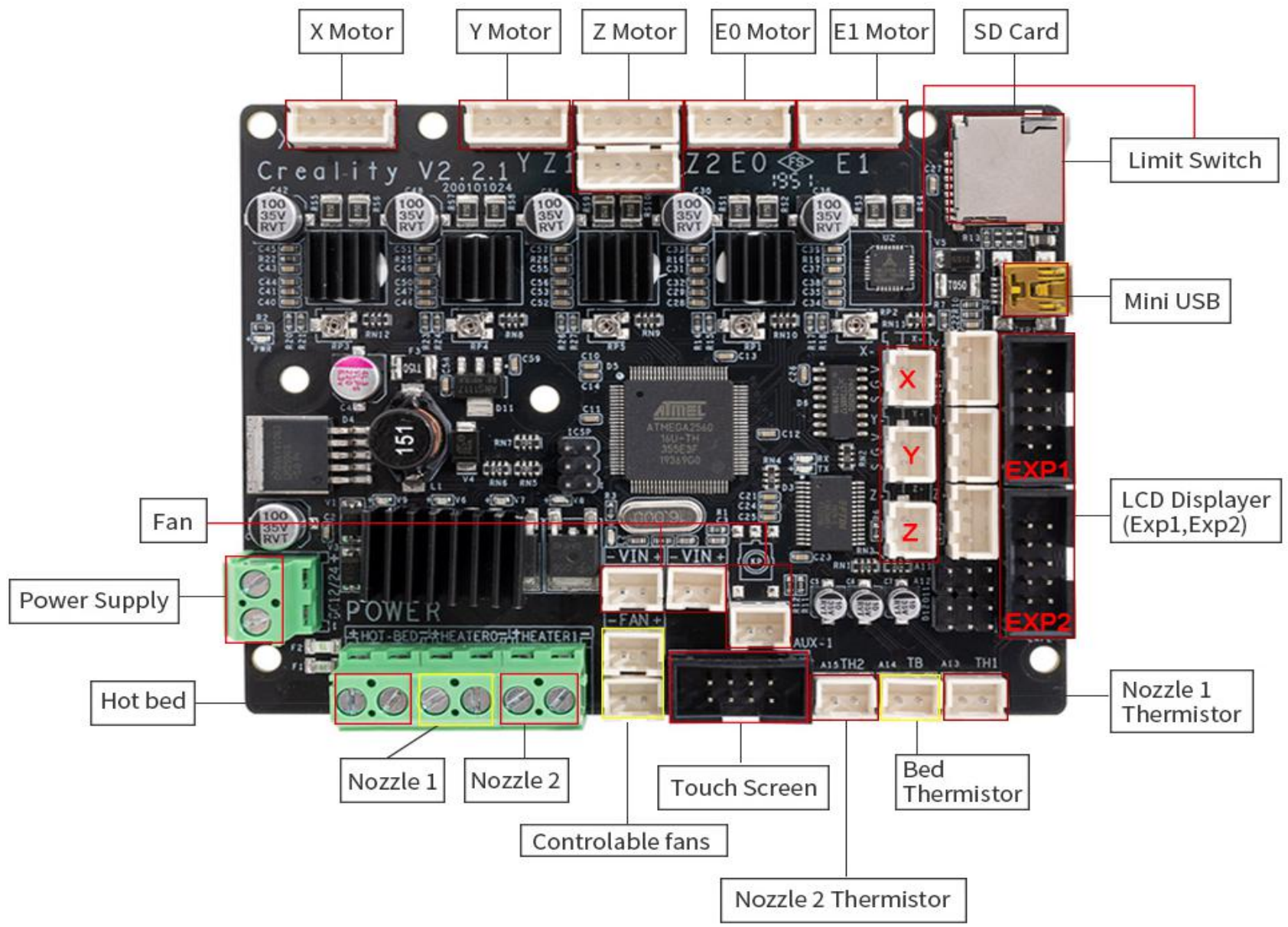

Service

1. The printer can be returned within seven days, 15 days replacement, one-year warranty, lifetime maintenance.

Every machine is assembled and tested by our expert staff before departing our facilities.

Replacement requirement

1. The appearance of the product is intact, without damage, cracks, deformation, etc.;
2. Machine is complete including all parts, tools, original box, and foam padding;
3. Provide a valid purchase invoice, product numbers should be the same.

Warranty coverage

1. The following accessories are not included in the warranty coverage (unless damaged by transportation): platform sticker; platform forming plate; acrylic cover; card reader and TF card; platform glass; USB cable; filament; rack and tools, etc.
2. Profile: Small blemishes in the black paint due to testing or shipping are not covered in the premise that the blemish does not affect normal use;
3. Nozzle assembly (nozzle, heating block, throat pipe , heat sink, Teflon tube, etc.) warranty period is 3 months. If damage occurs after the warranty expires, you will be responsible for replacement;
4. 12 Month Warranty on the motherboard, LCD display, power supply, heated bed. The free warranty maintenance is provided by the original factory over the warranty period. After Warranty expires, original factory maintenance is available, but the customer is responsible for shipping and maintenance costs;

Not included in warranty coverage:

- (1) It will be difficult to provide an effective warranty service if you can not provide a correct serial number;
- (2) The whole machine and components exceed the warranty period;
- (3) Equipment failure or damage caused by unauthorized modification of the equipment (private modification includes: 1. modification of the nozzle assembly; 2. modification of the machine structure; 3. use of third-party components; 4. use of third-party firmware procedures or change the original Factory firmware program, etc.);
- (4) Equipment failure or damage due to incorrect installation and use;
- (5) Equipment failure or damage caused by use in a non recommended working environment specified by this manual (Unstable, dusty, moisture);
- (6) Equipment failure or damage due to improper use (beyond workload, etc.) or maintenance;
- (7) Equipment failure or damage due to the use of other branded components or other inferior consumables.

SOVOL



Facebook QR Code



www.sovol3d.com

SHENZHEN Lian Dian Chuang Technology LTD.

Official Website: www.sovol3d.com

Tel: +86-0755-2107 4700

E-mail: sale@sovol3d.com info@sovol3d.com

